



ASSEMBLY INSTRUCTION
SAILOR 1400 OUTDOOR TABLE
ITEM CODE - 56215

Imported by Amart Furniture Pty Ltd, Qld, Brisbane Australia .
For any assistance with assembly or for missing parts please phone
Amart Furniture , Customer Service Freecall 1800 351 084



Imported by Amart Furniture Pty Ltd, Qld, Brisbane Australia .
For any assistance with assembly or for missing parts please phone
Amart Furniture, Customer Service Freecall 1800 351 084

PRE-ASSEMBLY PREPARATION



Before you start:

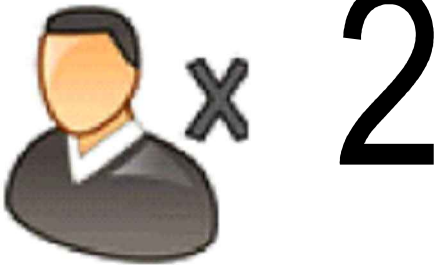
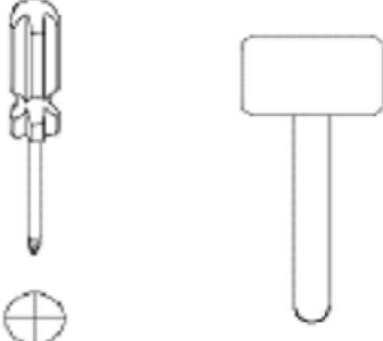



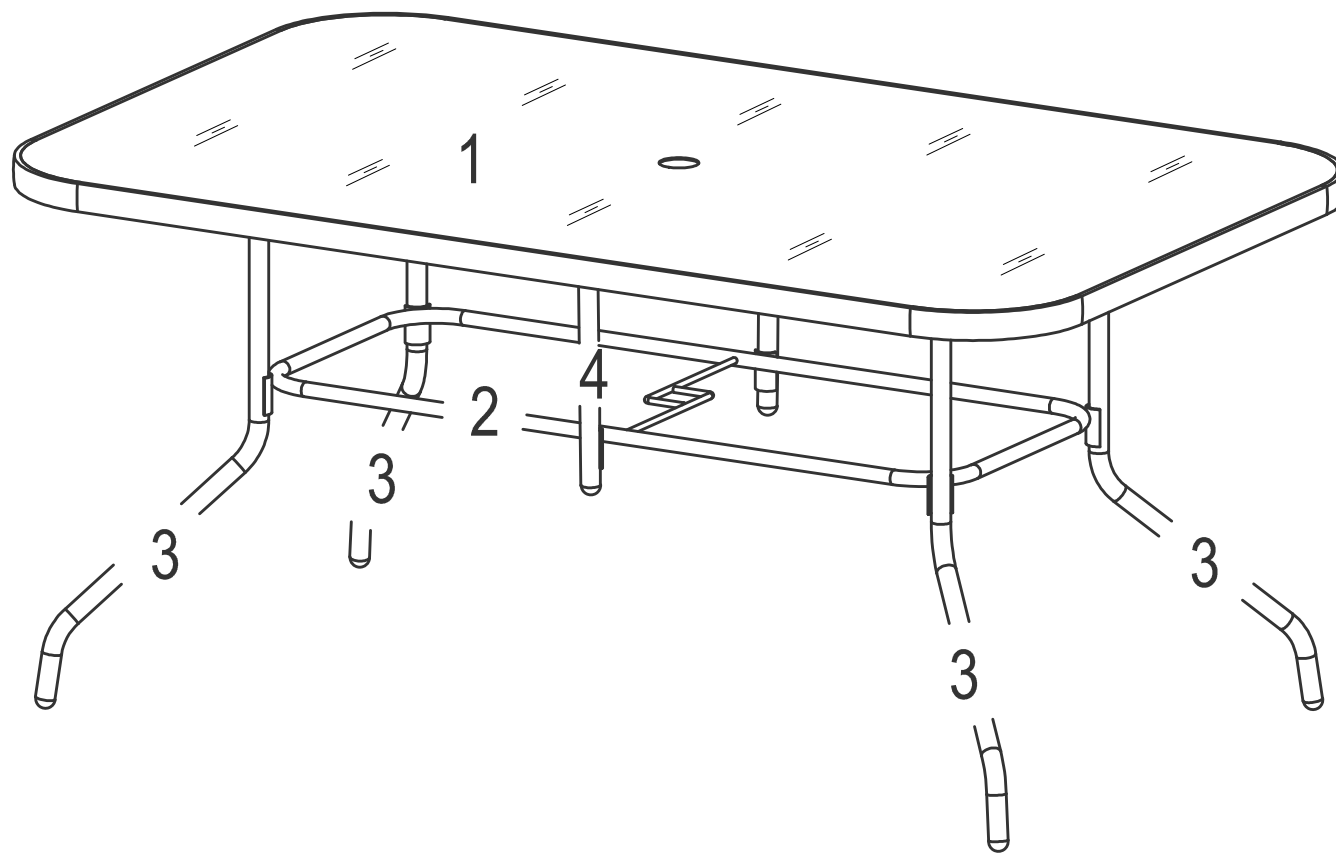

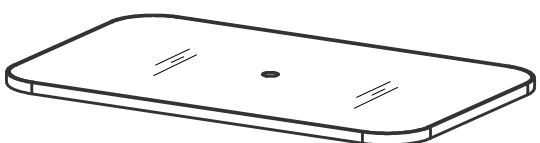
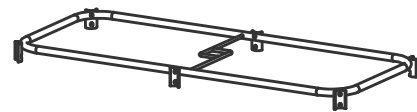
1. Choose a clean, level, spacious assembly area. Avoid hard surfaces that may damage the product.
2. Take care when lifting. Product should be assembled as near as possible to the point of use.
3. Ensure that you have all required contents for complete assembly.
4. Always read the assembly instructions carefully before beginning assembly.
5. Keep all hardware parts and packaging out of reach of small children.
6. Do not over tighten the screws and bolts as this may damage the threads.

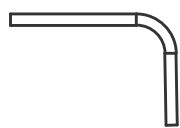
	
ALLOW 20 MINUTES	PEOPLE REQUIRED
	
ADDITIONAL TOOLS REQUIRED	

PARTS LIST

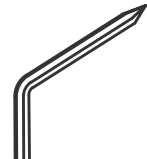

<p>1. Table Top 1PC</p> 	<p>2. Base Plate 1PC</p> 
<p>3. Legs 4PCS</p> 	<p>4. Legs 2PCS</p> 

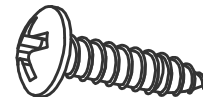
<p>A. Bolt</p>  <p>M6*35*6PCS</p>	<p>B. Bolt</p>  <p>M6*52*6PCS</p>	<p>C. Washer</p>  <p>M6*24PCS</p>	<p>D. Nut</p>  <p>M6*12PCS</p>
<p>E. Allen Key</p>  <p>M6*1PC</p>	<p>F. Wrench</p>  <p>M6*1PC</p>	<p>G. Screw</p>  <p>ST4*16*6PCS</p>	

Step 1:

ITEMS REQUIRED

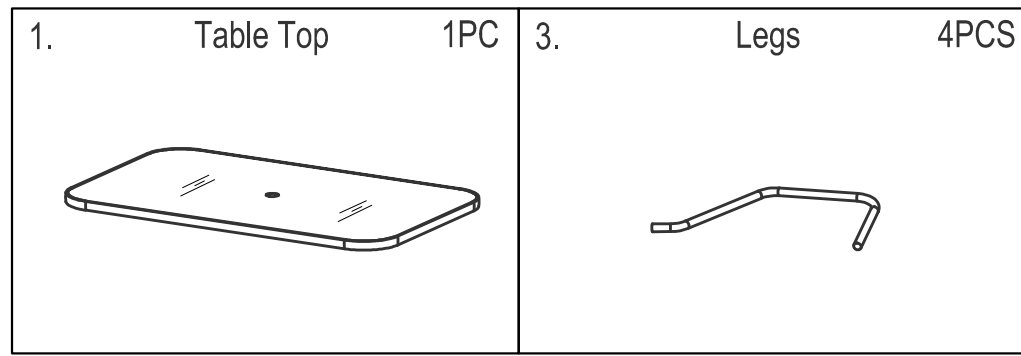

- Align holes in table top (1) over threads in table legs (3).

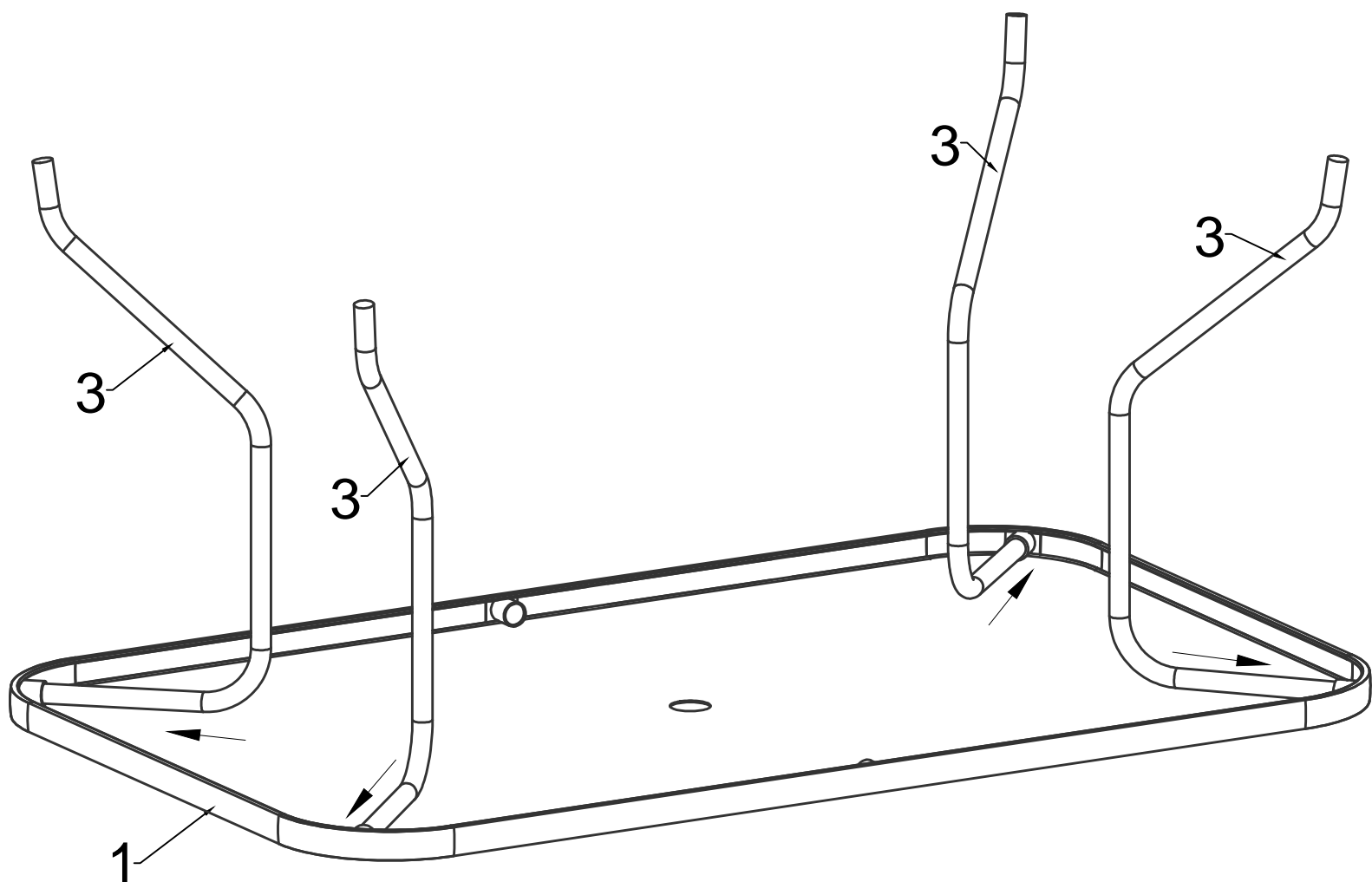

Step 2:

ITEMS REQUIRED

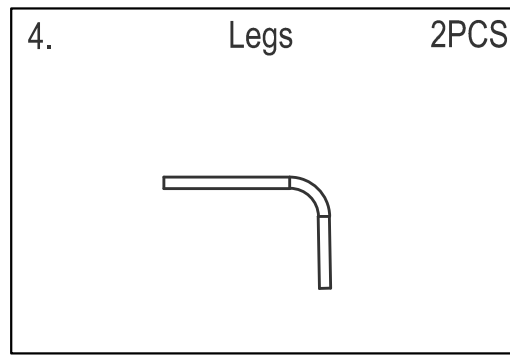

- Align holes in table top (1) over threads in table legs (4).

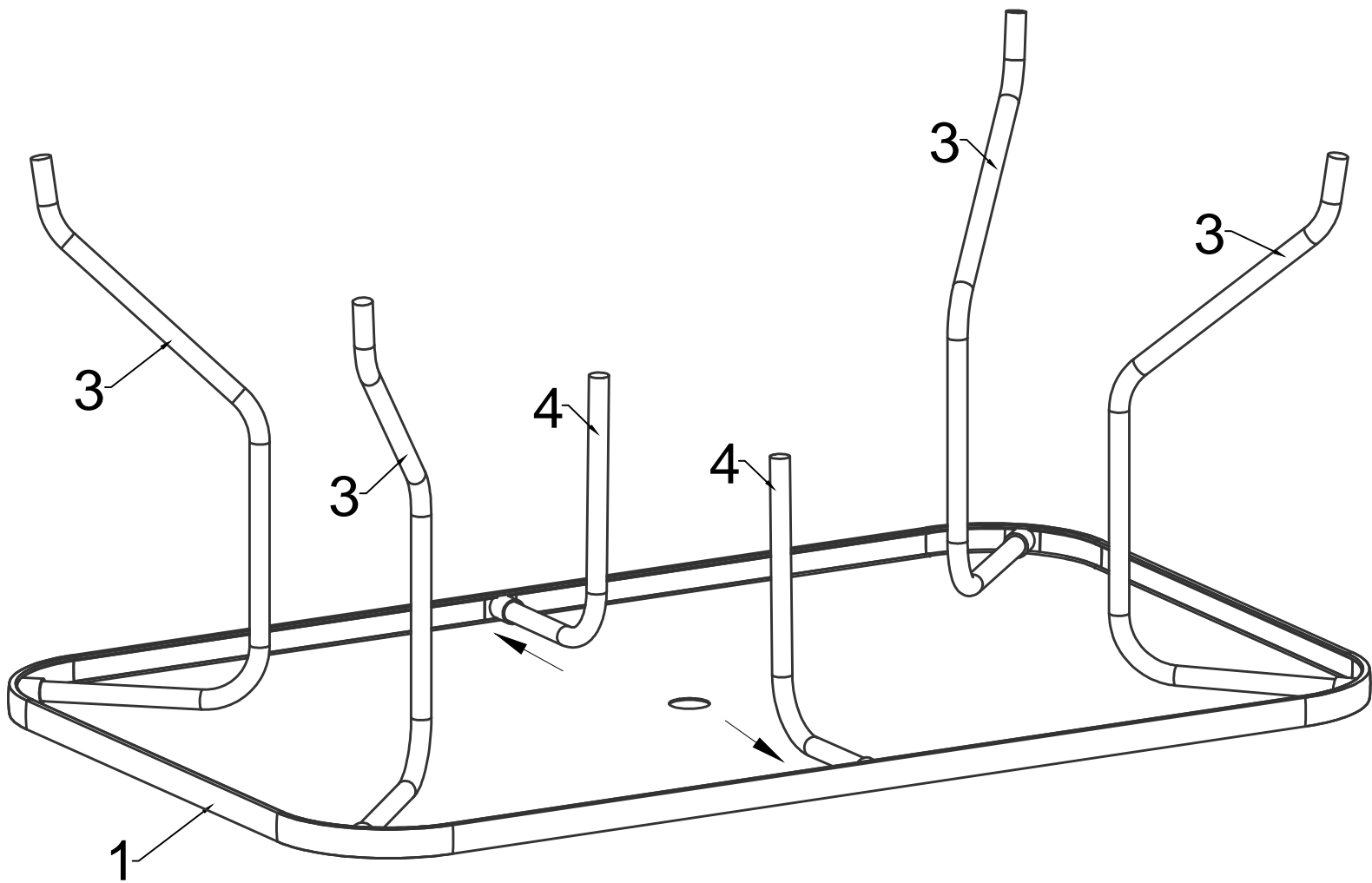

Step 3:

ITEMS REQUIRED

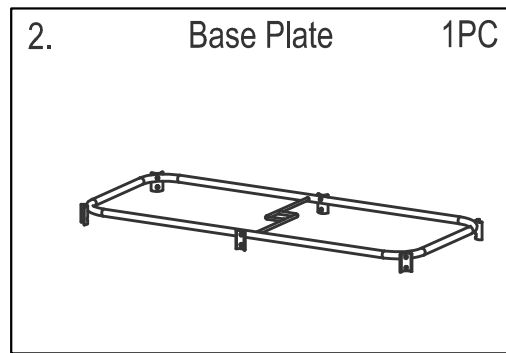



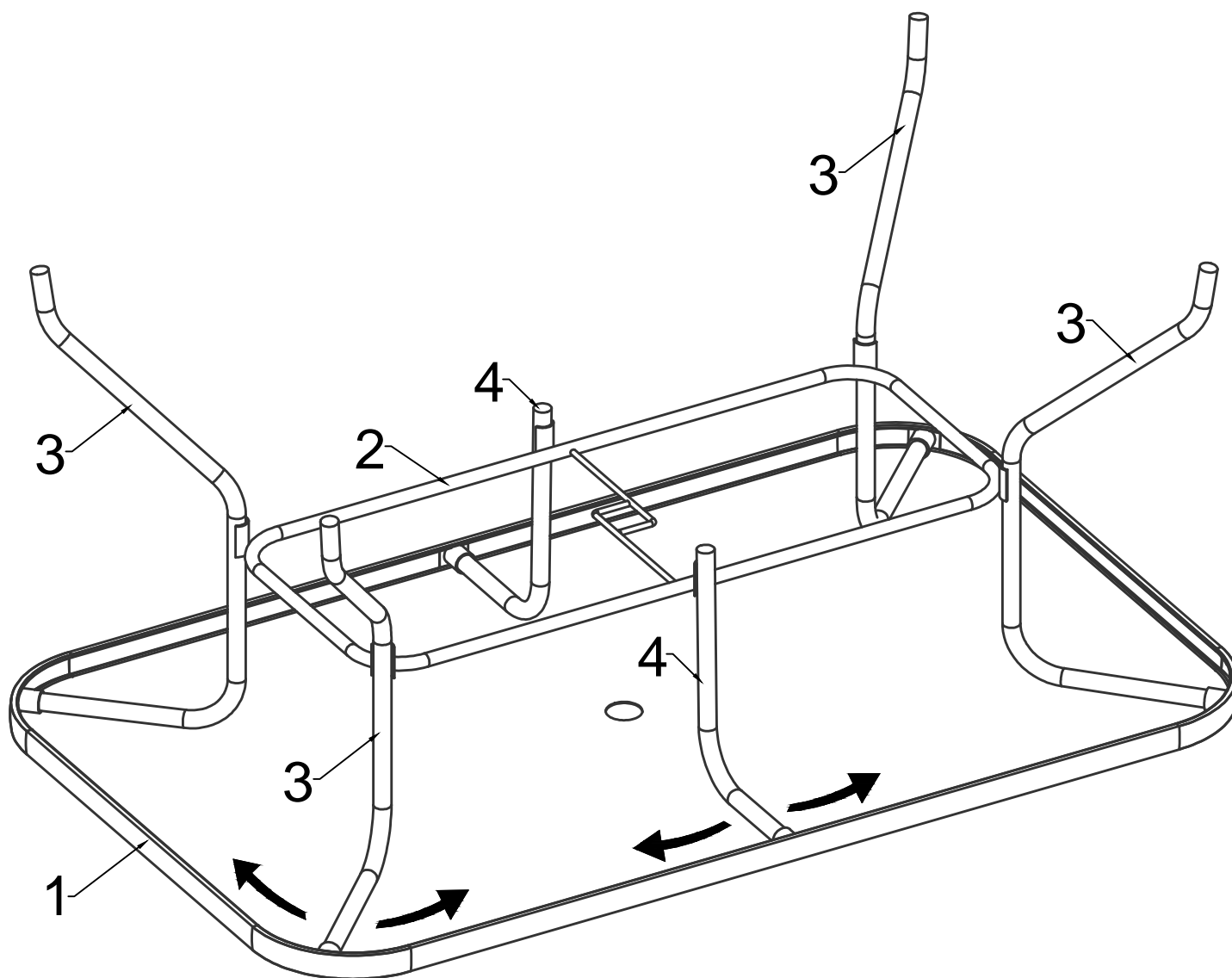

NOTES:

- Once the table legs are inserted, some slight adjustments may need to be made in order for the legs to be able to attach to base plate (2).
- This is done by gently repositioning the plastic housings in which the table legs screw in to .
- You can reposition the housings by gently tapping them with a rubber mallet or a similar soft surfaced tool.
- DO NOT USE A METAL HAMMER AS THIS MAY DAMAGE THE HOUSINGS.

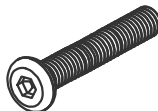

Step 4:

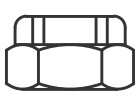
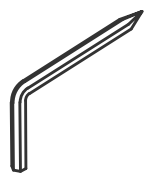
ITEMS REQUIRED

A. Bolt  M6*35*6PCS	B. Bolt  M6*52*6PCS	C. Washer  M6*24PCS	D. Nut  M6*12PCS
E. Allen Key  M6*1PC	F. Wrench  M6*1PC		

- Attach table legs (3) and legs (4) to base plate (2) using bolt (A) and bolt (B) and nut (D) with washer (C) .
- Insert all bolts before fully tightening .
- Tighten with allen key (E) and wrench (F) .

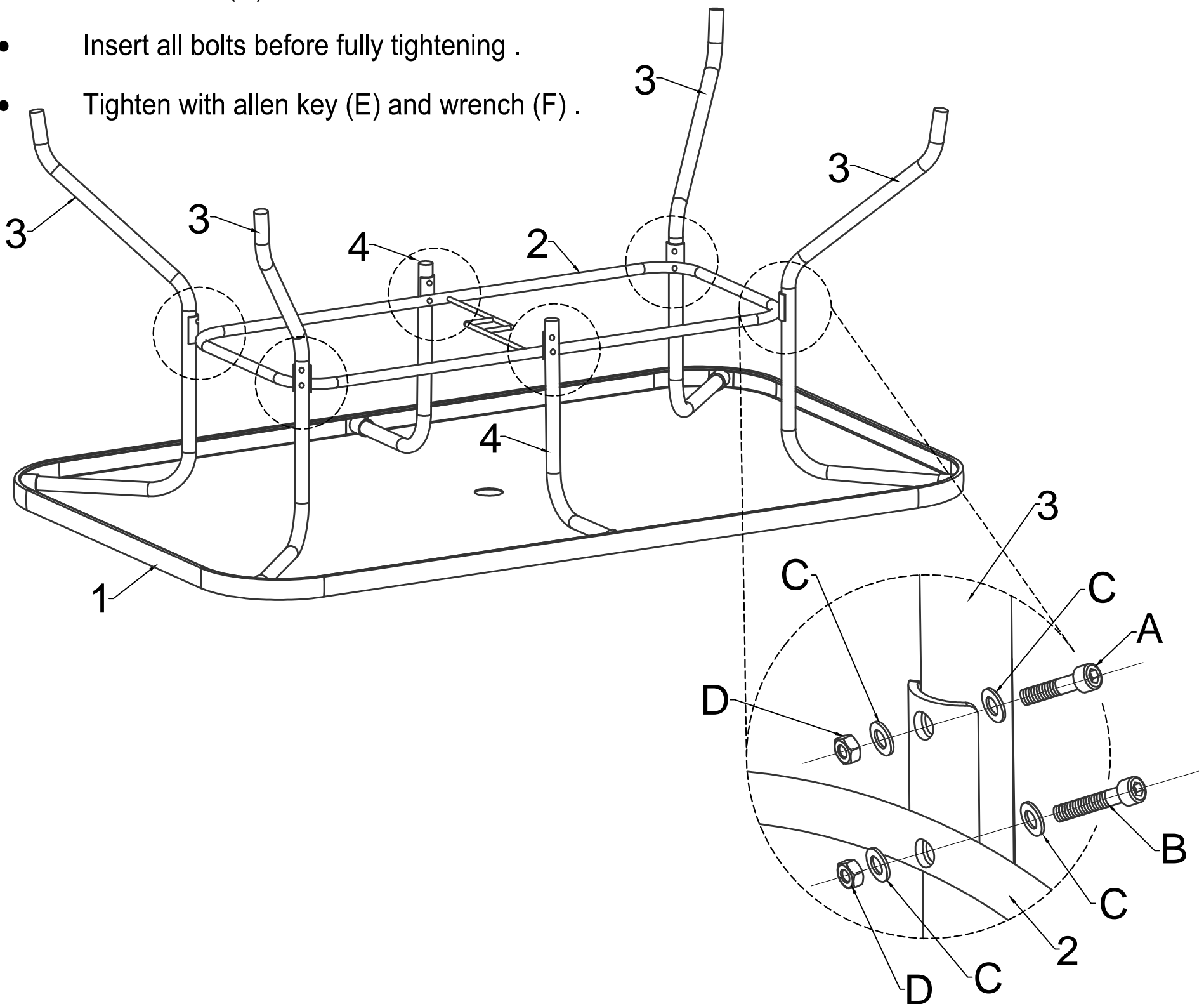

Step 5:

ITEMS REQUIRED

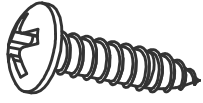
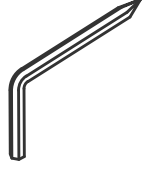
G.	Screw	4PCS	E.	Allen Key
				
			M6*1PC	

- Attach table legs (3) and legs (4) to table top (1) using screw (G).
- Tighten with allen key (E) .

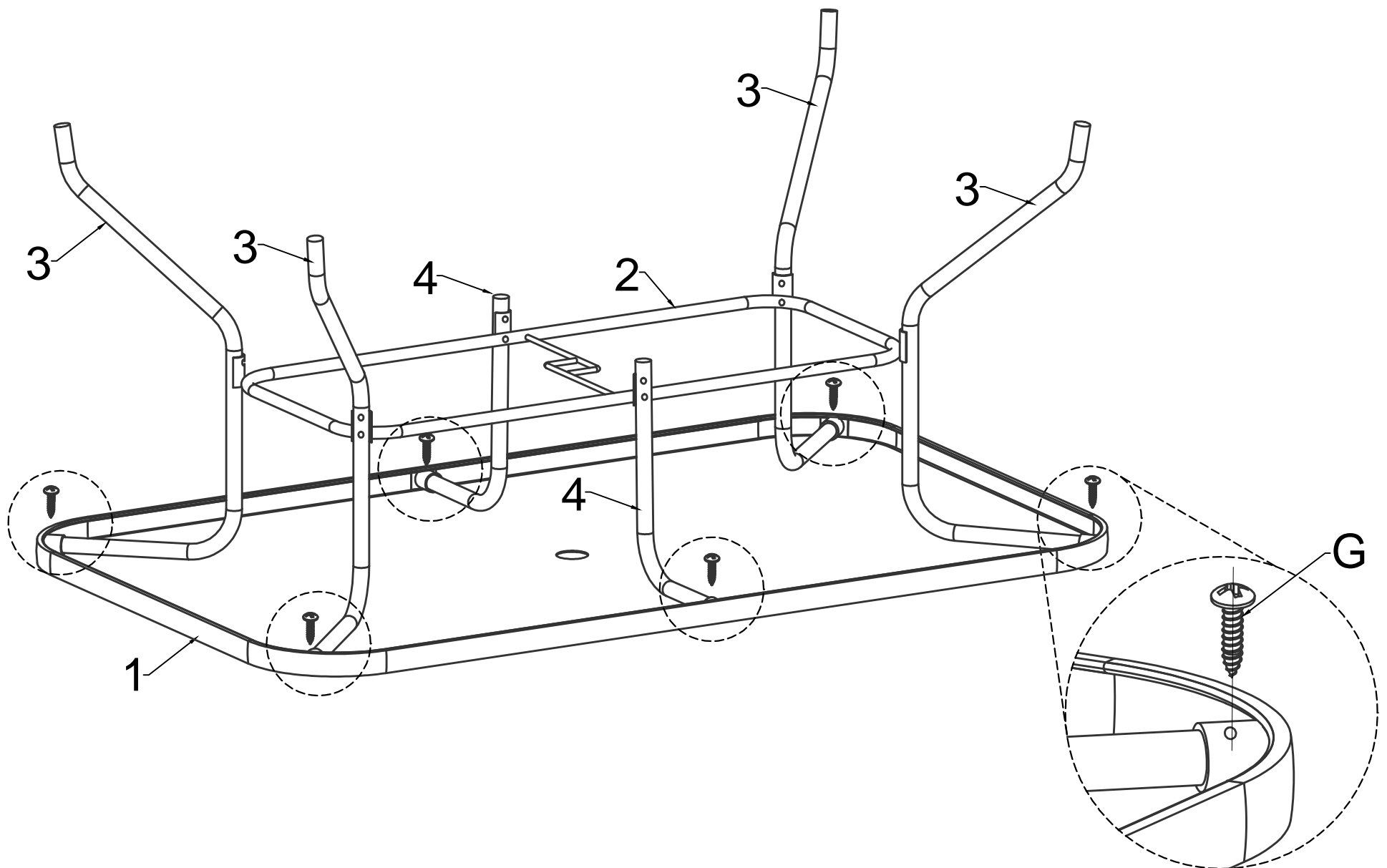

ASSEMBLY IS COMPLETE



Care and maintenance



Metal

- ☒ Item is designed for use outdoors. However we do not recommend leaving this product outside when not in use. To preserve the life of this item, avoid prolonged exposure to the elements & store inside/under cover or use an outdoor cover.
- ☒ DO NOT allow the furniture to be left in the rain or left wet for extended periods of time.
- ☒ Wipe furniture Dry immediately after it becoming wet.
- ☒ DO NOT clean your furniture down with any harsh solvents, abrasives or chemicals.
- ☒ To remove dirt and grime, simply rinse with fresh water or periodically clean using a sponge and mild detergent solution as required

Glass

- ☒ If the glass is chipped or broken, stop using the product and consult place of purchase .
- ☒ Do not drop, drag or strike glass .
- ☒ Do not sit or stand upon the glass surface .
- ☒ Do not place very hot or cold items on the glass surface unless adequately thick table mats are used to prevent such items coming in contact with the glass .
- ☒ Do not place heavy objects on glass .
- ☒ Avoid scratching the glass or using as a chopping surface .
- ☒ Do not strike the glass with hard or pointed items .
- ☒ When cleaning the glass panels use a damp cloth with washing up liquid or soft soap if necessary. Do not use washing powders or any other substances containing abrasives since these may scratch the glass.